

NATIONAL RADIO INSTITUTE

Washington D. C.

Radio-Trician Service Manual

REG. U. S. PAT. OFF.

Compiled solely for  Students & Graduates

ON

THE PHILCO SCREEN GRID MODELS 65, 76 AND 95 RECEIVERS

The Philco A. C. screen grid receiver Model 65 employs three tuned stages, the detector stage and a stage of push-pull amplification. The Screen Grid Tubes are used in the two R. F. stages. The —45 type power tubes designed for A. C. set operation are used in the stage of push-pull audio amplification.

The ground terminal shown on the schematic diagram, Fig. 1, is electrically connected to the chassis which is used as a return lead. All the ground connections shown in the schematic diagram are connected to the chassis. The antenna terminal is connected directly to the first R. F. transformer, with a 10,000 ohm resistor, bridged across the primary. This transformer has been designed for use with the Screen Grid Tube and is tuned by the first section of the tuning condenser. There is a fixed compensating condenser connected across the first section of the tuning condenser. This compensates for capacities introduced in the wiring by the other R. F. transformers which are somewhat different in construction from the first. Another compensating condenser, not shown on the diagram, is bridged across the first section. This is the compensator that is built into the condenser unit.

The connections to the first screen grid tube are made in the regular manner to the base of the tube and with a flexible lead from the first tuning condenser to the control grid of the tube. (The control grid of the screen grid tube corresponds to the regular grid of other tubes. The grid shown in the schematic diagram, between the control grid and the plate of the tube, is the screen grid.) The plate of the first tube is connected to the second R. F. transformer. This trans-

former is tuned by the second section of the tuning condenser which also has a compensating condenser built in with it, though not shown in the schematic diagram. The same procedure is followed, the third R. F. transformer being tuned by the third section of the tuning condenser. There is, however, no compensating condenser built into the third section.

Neither grid leak nor condenser is required in the detector stage as a biased detector is used. An R. F. choke coil is inserted in the plate lead of the detector to keep the R. F. current from the audio circuit. Two audio transformers are used, first the input transformer designed for push-pull operation, and the output transformer, a special push-pull transformer for coupling the receiver to the electro-dynamic speaker.

It is extremely important that all parts of the receiver be well shielded. The use of the Screen Grid Tubes allows the use of the full amplification of the tubes without setting up any oscillation or regeneration. It is not necessary to neutralize in any way the Screen Grid receiver. This has been taken care of by the design of the tubes and the receiver. The shields are not shown on the schematic diagram although each R. F. stage is effectively shielded from other stages.

The volume is controlled by regulating the voltage of the Screen Grid of the R. F. tubes. The B and C voltages for the tubes are supplied by a full wave rectifier.

Testing and Servicing

Figure 1 is a schematic diagram of the receiver and speaker circuit. The numbers enclosed in the circles in the sche-

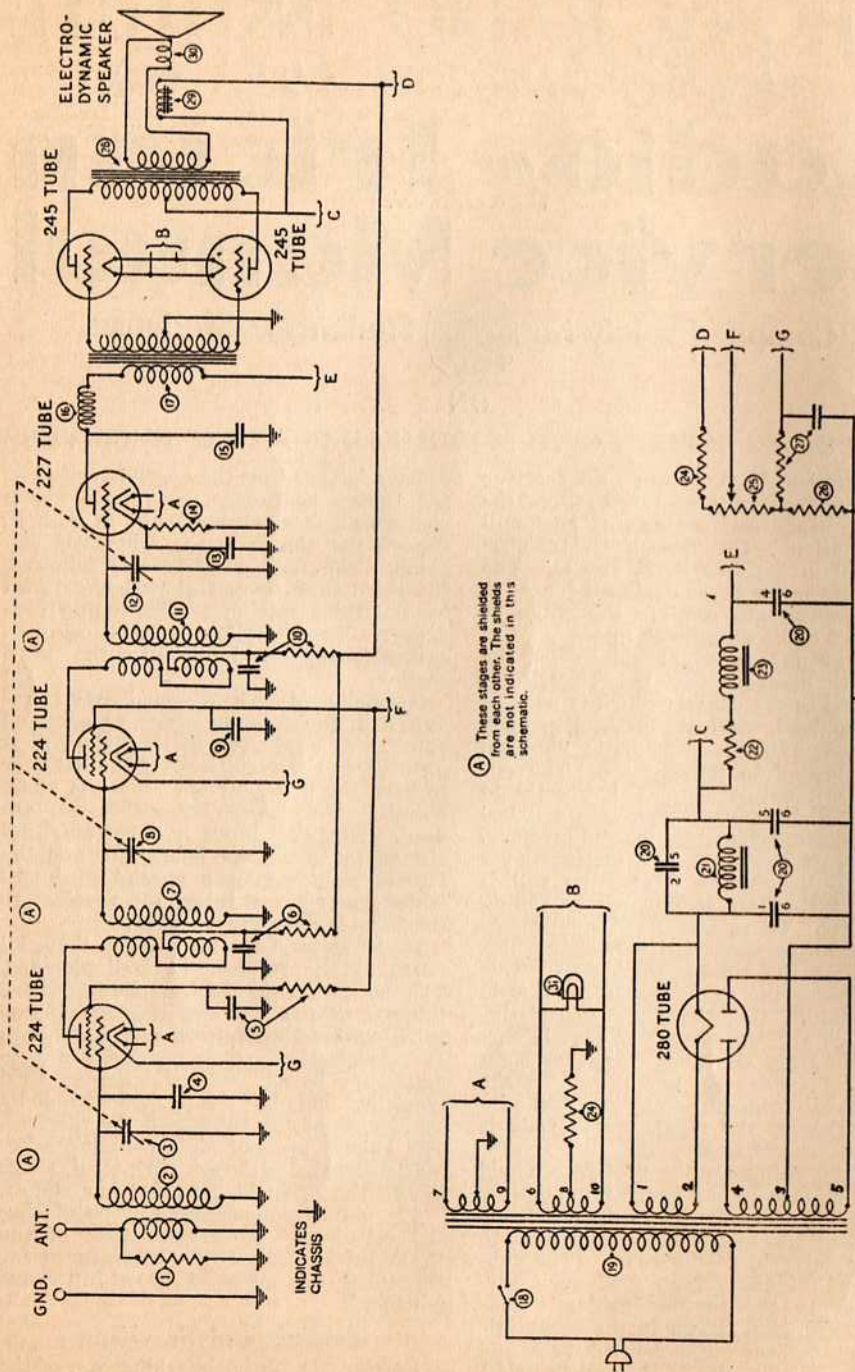

Fig. 1—Schematic Diagram of Philco Screen Grid Receiver, Model 65.

matic diagram refer to the different parts used. Table 1 lists these numbers and the apparatus which they indicate.

IMPORTANT NOTICE. The power transformers in a few of the first receivers manufactured had different terminal numbers than those shown in Figure 1. In such receivers the figures in the Figure 1 should be changed as follows: Change No. 1 to No. 4, No. 2 to No. 5, No. 4 to No. 1 and No. 5 to No. 2. This change is necessary on only a very few of the first models manufactured.

Before doing any service work on receivers, make sure that the trouble is not due to some external condition such as a poor antenna and ground, poor contact in the A. C. receptacle or defective tubes.

lead from an oscillator is connected to first, the stator of the third tuning condenser; second, the stator of the second tuning condenser; third, the stator of the first tuning condenser. With the receiver tuned to the oscillator frequency the signals should be heard and should increase in strength in each succeeding position. If the signal is heard when testing at one point but does not increase at the following points the trouble lies between the two test points.

DEFECTIVE TUBES: Replace the tubes one at a time using a good tube of the proper type noting the improvement. If the complaint has been that the set fades, is noisy or hums, it is especially important to try one or more —27 or —24 type tubes.

TABLE NO. 1.

1. Antenna Resistor.	10. By-Pass Condenser and Plate Resistor.	21. First Filter Choke.
2. R. F. Transformer (Antenna Coil).	11. R. F. Transformer.	22. Detector Plate Resistor.
3. Tuning Condenser.	12. Tuning Condenser.	23. Second Filter Choke.
4. Fixed Compensator.	13. Cathode By-Pass Condenser.	24. B. C. Resistor.
5. By-Pass Condenser and Screen Grid Resistor.	14. Cathode Resistor.	25. Volume Control.
6. By-Pass Condenser and Plate Resistor.	15. By-Pass Condenser (Detector Plate).	26. Resistor.
7. R. F. Transformer.	16. R. F. Choke.	27. By-Pass Condenser and Cathode Resistor.
8. Tuning Condenser.	17. Push-Pull Input Transformer.	28. Push-Pull Output Transformer.
9. By-Pass Condenser.	18. Set Power Switch.	29. Field Windings.
	19. Power Transformer.	30. Voice Coil and Cone.
	20. B Filter Condenser.	31. Pilot Lamp.

Too much emphasis cannot be placed on seeing that the trouble present is not due to any one of these causes.

On checking a receiver that will give no signals, first determine whether the trouble is in the R. F. or the A. F. side. Allow the detector tube to become thoroughly heated. Removing the detector tube from its socket will cause a loud click in the speaker if the circuit is right between the detector and speaker, and indicates trouble in the R. F. circuit. If no click is heard when the detector tube is removed the trouble lies in the A. F. circuit. The A. F. circuit can be tested by connecting a pair of headphones in front of it to act as a pick-up. The easiest method of doing this is to use a phonograph pick-up adapter in the detector socket. The two terminals of the phonograph pick-up adapter connect with the plate and cathode of the detector socket, and can be connected to the headphones. Any sounds transmitted into the headphones will be reproduced in the loud speaker if the audio circuit is right.

To test the R. F. side of the receiver an oscillator can be used to an advantage. A test should be made when a

NO VOLTAGE ON THE RECEIVER: This indicates a poor connection or open in the A. C. receptacle or the A. C. plug, a defective switch or transformer.

INCORRECT VOLTAGE ON ONE OR MORE TUBES: Due to variations in tubes, the voltage readings obtained at the tube socket will vary slightly from those given in Table 2. If a set tester is used to test the voltages at each socket, and large variations from the values given in Table 2 are found, the cause should be determined.

GROUNDING ANTENNA: In this case no signals will be heard. Thoroughly test the entire antenna installation. If the ANT terminals on the receiver or the lead going to it are grounded to the metal base the reception will be cut out.

OPEN ANTENNA CIRCUIT: This will diminish the signal strength and only the most powerful stations will be audible. To check the internal antenna circuit, disconnect the antenna from the ANT terminal. Attach the antenna lead tie bar on the stator of the first tuning condenser. If normal reception is obtained the trouble is an open circuit be-

TABLE NO. 3
Voltage Readings for Model 76

Tube		Filament Volts	Plate Volts	Screen Grid Volts	Control Grid Volts	Cathode Volts	Plate Milli-amperes	Screen Grid Milli-amperes
Type	Circuit							
224	1st R.F.	2.3	145	90	3	13	3.5	.4
224	2d R.F.	2.3	145	90	3	13	3.5	.4
224	Detector	2.3	36*	30†	1.4	12	0	0
227	1st A.F.	2.3	140		1	10	3	
245	2d A.F.	2.2	230		46		30	
245	2d A.F.	2.2	230		46		30	
280	Rectifier	4.5					50	

All readings taken with antenna disconnected and ground on. Volume control on full. Local-Distance Switch in Distance position.

*Read with a 250,000-ohm voltmeter.

†Read with a 100,000-ohm voltmeter.

TABLE NO. 4
Power Transformer Voltages for Model 76

Terminals	A. C. Volts	Secondary
1		Center Tap for 280 Plate
2		Center Tap for 245 Tubes
3- 4	2.67	Heaters of 224 and 227 Tubes
5- 6	2.68	Filaments of 245 Tubes
8- 9	5.00	Filament of 280 Tube
7-10	750	Plate of 280 Tube
Red Wire		Center Tap for 224 and 227 Tubes
Red Wire		Primary
Red Wire		Primary

TABLE NO. 5
Condenser Data for Model 76

Lugs No.	Capacity	D. C. Volts With Receiver Turned On
1-7	2.0 MF	145
4-5	.15 MF	21*
2-5	2.0 MF	295
2-6	2.0 MF	310

*Read with a 250,000-ohm voltmeter.

TABLE NO. 6
Resistor Data for Model 76

Number From Diagram on Page 5	Resistor Terminal	Ohms Resistance	Voltage Drop
(27)	1-2	1,400	40
	2-3	1,500	40
	3-4	2,000	55
(29)	1-2	250	11
	2-3	800	46
(2)		20	
(3)		5,000	
(14)		100,000	
(17)		250,000	
(19)		500,000	
(20)		100,000	
(22)		500,000	
(28)		125	

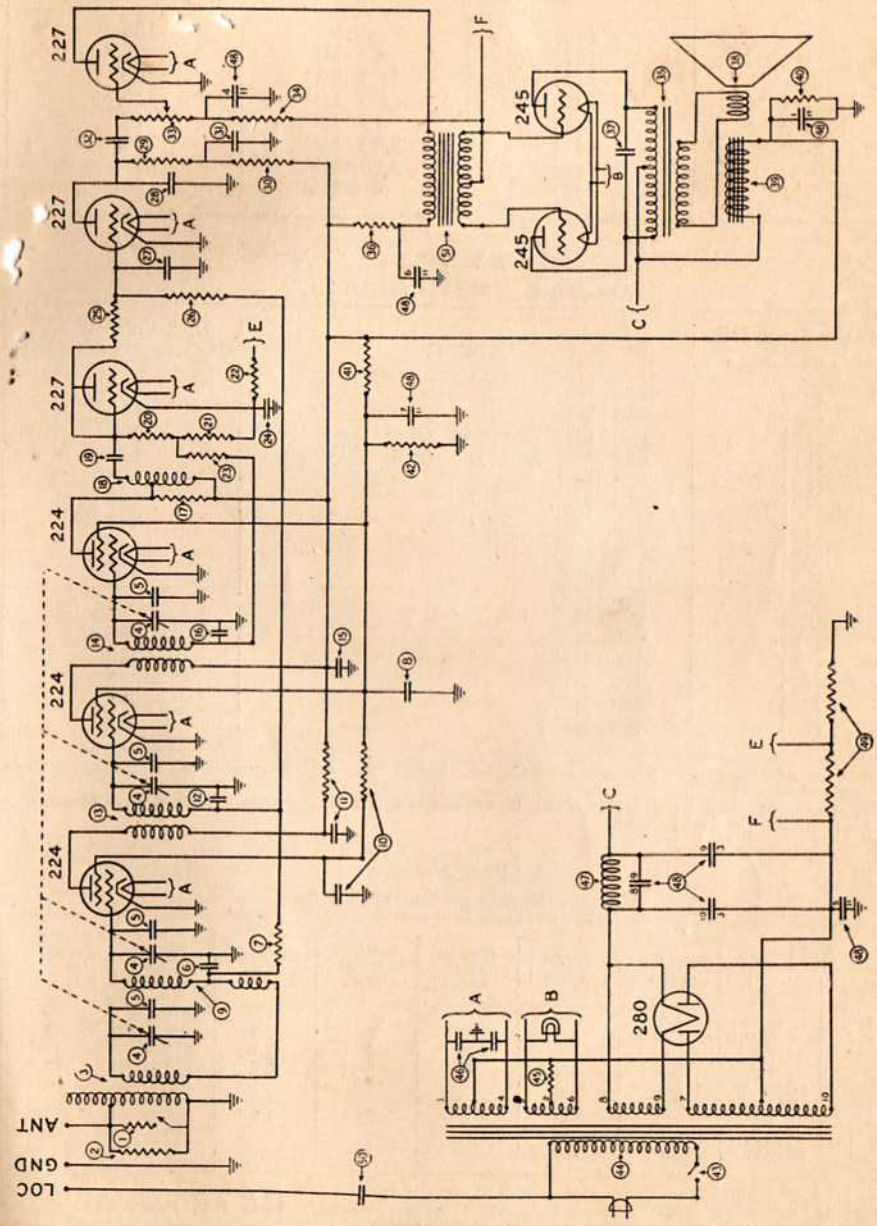

Fig. 3—Schematic Diagram of Model 95

TABLE NO. 7
"B" Filter Condenser Block for Model 95

Lugs No.	Number From Diagram on Page 7	Capacity	D.C. Volts With Receiver Turned On
1-11	(48)	1.00 MF	155
4-11	(48)	.50 MF	.7
6-11	(48)	1.00 MF	90
7-11	(48)	1.00 MF	110
8- 9	(48)	.15 MF	18
3- 9	(48)	2.00 MF	300
3-10	(48)	2.00 MF	338
5-11	(48)	.015 MF	5.3

TABLE NO. 8
Condenser Data for Model 95

Number From Diagram on Page 7	Capacity	D.C. Volts With Receiver Turned On
(6)	.015 MF	*
(8)	.050 MF	110
(10)	.050 MF and 250 Ohm Resistor	110
(11)	.050 MF and 250 Ohm Resistor	155
(12)	.015 MF	*
(15)	.050 MF	155
(16)	.015 MF	300
(19)	.0005 MF	*
(24)	.500 MF	**
(27)	.0025 MF	*
(28)	.0025 MF	*
(31)	.050 MF	66
(32)	.015 MF	30
(37)	.015 MF	*
(46)	.250 MF	**
(50)	.015 MF	*

*No voltage reading will be obtained across these. Check for break-down with a voltmeter with battery in series.
**Voltage reading will be obtained even if condenser is open. Unsolder condenser and check with meter and battery for break-down.

TABLE NO. 9
Voltage Readings for Model 95

Tube		Filament Volts	Plate Volts	Screen Grid Volts	Control Grid Volts	Cathode Volts	Plate Milli-amperes	Screen Grid Milli-amperes
Type	Circuit						43/Plate	
280	Rectifier	4.5						
224	1st R.F.	2.15	155	95	0	5.3	4	.8
224	2d R.F.	2.15	155	95	0	5.3	4	.8
224	3d R.F.	2.15	155	95	0	5.3	4	.8
227	Detector	2.15	0		-.5	.7	0	*
227	Det. Amp.	2.15	27		-.5	5.5	0	
227	1st A.F.	2.15	85		-2.0*	5.5	2.5	
245	2d A.F.	2.2	250		41		28	
245	2d A.F.	2.2	250		41		28	

*This is read with Volume Control off. With it on the reading will be .2 volt.
NOTE: Do not allow receiver to oscillate while taking readings. Keep R.F. shield on and tune to eliminate oscillation. Have antenna and ground connected.