



NATIONAL RADIO INSTITUTE

 *Washington D. C.* 

Radio-Trician Service Manual

(TRADE MARK REGISTERED U. S. PATENT OFFICE)

Compiled solely for  Students & Graduates

ON THE

GREBE SYNCHROPHASE AC-6, AC-7 AND SUPER SYNCHROPHASE SCREEN GRID SK-4 RECEIVERS

SYNCHROPHASE AC-6

The Synchronphase A. C. 6 circuit employs three tuned Radio frequency stages, using three —26, one —27 and one —71-A type tubes. A wiring diagram of this receiver and power supply unit is shown in Figure 1.

Hum and Noises in A. C. 6

To further reduce the hum to a minimum the hum-adjuster in the form of a potentiometer across the 226 type tube filaments is provided and may be reset if found necessary.

Microphonic or defective tubes are not an uncommon cause of trouble. For this reason all tubes should be checked very carefully if undue hum or noise is encountered.

The Radio-Trician should distinguish between the various types of hum, especially between 60 and 120-cycle tones. A 60-cycle hum may be demonstrated by throwing the hum adjuster off the neutral point. A 120-cycle hum may be produced by short-circuiting the filter choke posts on power unit. This latter cannot be tried if a D.C. dynamic speaker is used, deriving field supply, from power pack.

Sixty-cycle hum is due to tube filaments. The hum adjuster may be off-center or a connection open. The 171-A or 227 center-tap resistor may be open, or filament leads to power pack loose. The pilot lamp or leads may be grounded, which will also heat and burn out the 171-A center-tap resistor. Defective or improperly "aged" 226 tubes will cause 60 (sometimes 120) cycle hum. Opera-

tion for a few hours with normal filament, and twice normal plate current has been found effective as an aging process.

120-cycle hum is generally due to faults in the B-C supply. Low line voltage is one possibility. B and C voltages should be checked carefully. The C bias on the R.F. and first A.F. tubes must be 4.5 to 5, and may cause hum if not correct. A poor ground connection at the socket supporting screw in the power unit will cause hum, especially in console installations; the metal base of the table model makes a good connection. Reversal of leads in repairing a power pack will set up hum, especially those from the choke to C1 and C2, and those to the 750-ohm "growl" resistor.

Heater elements and cathode of the 227 detector tube in many cases will develop a buzzing noise different from the other humming sounds herein described, this being an internal defect of the tube and can only be rectified by replacing the tube. However, in the majority of cases this buzzing will develop sooner or later in some makes of tubes. The test for this condition is to short-circuit the upper grid leak clip of the detector tube isolating circuit to the deck with a screw-driver which eliminates possibility of the hum coming in from the R.F. tube, and to remove the detector tube from its socket when the buzz is heard or short the primary of the first A.F. Transformer. If the latter eliminates the noise and the first test does not, the trouble is clearly in the detector tube.

Synchrophase A.C. 7

The Synchrophase Model 7 A. C. uses five —26, one —27 and one —71-A tubes. Figure 2 gives a wiring diagram of

this receiver and of the power unit. Instead of employing the usual method of dividing voltages in the power unit itself, correct voltages are supplied to

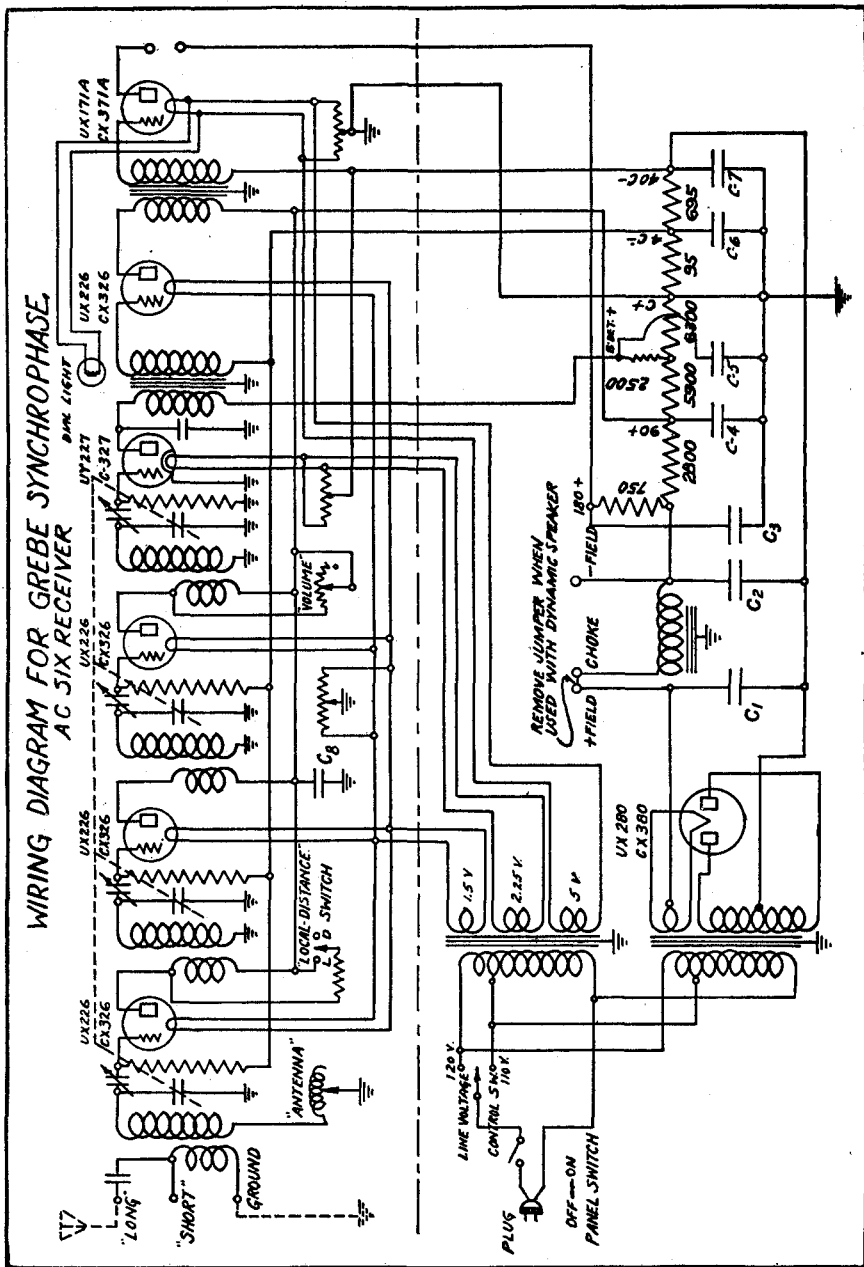

Fig. 1—Wiring Diagram of Grebe Synchrophase A. C. 6.

the receiver by means of a voltage dividing system located beneath the aluminum deck.

The power unit has only two direct current terminals and delivers the total rectified voltage to the receiver terminal strip through the cable, to be divided as required by the resistances inside the set. The two leads are designated as B+ and C- and coded red, and black and green tracer, respectively. The C- lead is grounded to the deck instead of grounding all filaments (cathodes) as is done in the Grebe A.C.-Six model.

CAUTION.—It has been a common practice to test tubes by placing them in the receiver tube sockets in place of the original tubes used in the set while in operation. This procedure is not recommended with the Synchrophase Seven A.C. receiver due to the fact that it is natural for a high voltage to occur across the B+ and C- terminals of the power unit when there is no load, which might damage the filter condensers. If a single 226 or 227 type tube becomes defective or is removed the voltages will not be appreciably affected. However, if the 171-A type power tube is removed while the set is in operation, high-voltage surges may be produced across the filter condensers of the power unit causing them to break down.

The same high voltage surges result from the switching of loud speaker leads while the set is in operation, since the plate circuit of the power tube is thereby opened and closed. If the Synchrophase Seven A.C. is used for speaker comparisons or tests, the use of an output transformer or output filter device is suggested. A shorted filter condenser will generally cause excessive heating of the rectifying tube causing the plates to become a dull red, or emitting a bluish glow.

Super Synchrophase Screen Grid Model SK-4

The Super-synchrophase screen grid receiver uses three —24, one —27 and two —45 tubes. A wiring diagram of this receiver and also the power supply is shown in Figure 3.

Oscillation

A good ground is very essential for the proper performance of the SK-4.

Tubes are frequent offenders toward oscillation. Experience indicates that standard tubes (such as RCA and Cunningham) are the safest to use since the

instrument was designed primarily to match the characteristics of these tubes. Although the specifications of independently manufactured tubes of identical types have approximately the same characteristics, cases have been found where they vary considerably and were the direct cause of oscillation.

It may possibly happen with a brand new set of tubes and the volume control advanced to full "on position," that a tendency to oscillate may be encountered. It is not advisable, however, to effect any changes in the factory adjustments of the set until after these tubes have been in use for a few days. It is very probable after a short time that the high emission from the new tubes will pass off—the set will then stabilize itself, and if no adjustments have been made the receiver's maximum efficiency will then be maintained.

Location of the aerial lead-in is important, regardless of the total shielding employed. The aerial lead should not run along close to the back of the radio amplifier chassis.

It will generally be found that suggestions given above will correct most all oscillating receivers. If, after the above conditions have been investigated and corrective measures applied, the set still has a tendency toward oscillation, further suggestions are offered.

CONTACT BRAKE ADJUSTMENT.—Located between rotors of the tuning condensers are three "contact-brakes" so called because they serve a double purpose, acting as a contact for the condenser rotors and also to give a braking action. Oscillation may be attributed to poor contact at these points. Tightening is suggested. Care should be exercised in tightening the contact-brakes. If they are made too tight the tuning wheel will turn exceedingly hard. Brakes should always be tightened, so each has equal pressure. To determine if contact-brakes are the cause of oscillation, they may be set hard to determine whether this corrects the trouble, then released equally until tuning is smooth and where oscillation is not experienced.

In making adjustments to the contact-brakes it is necessary that the condenser cover shield be removed—this is done by loosening the four bolts holding the cover in place, two of which are located at the far end of the six-gang condenser mounting.

FLEXIBLE LEAD POSITION.—The correct position of the black flexible

leads above deck running from the compensator adjuster lugs on each condenser into the shielded coil is important. These

ADJUSTABLE GAIN SCREWS.—There are three adjustment screws protruding through the base of the radio

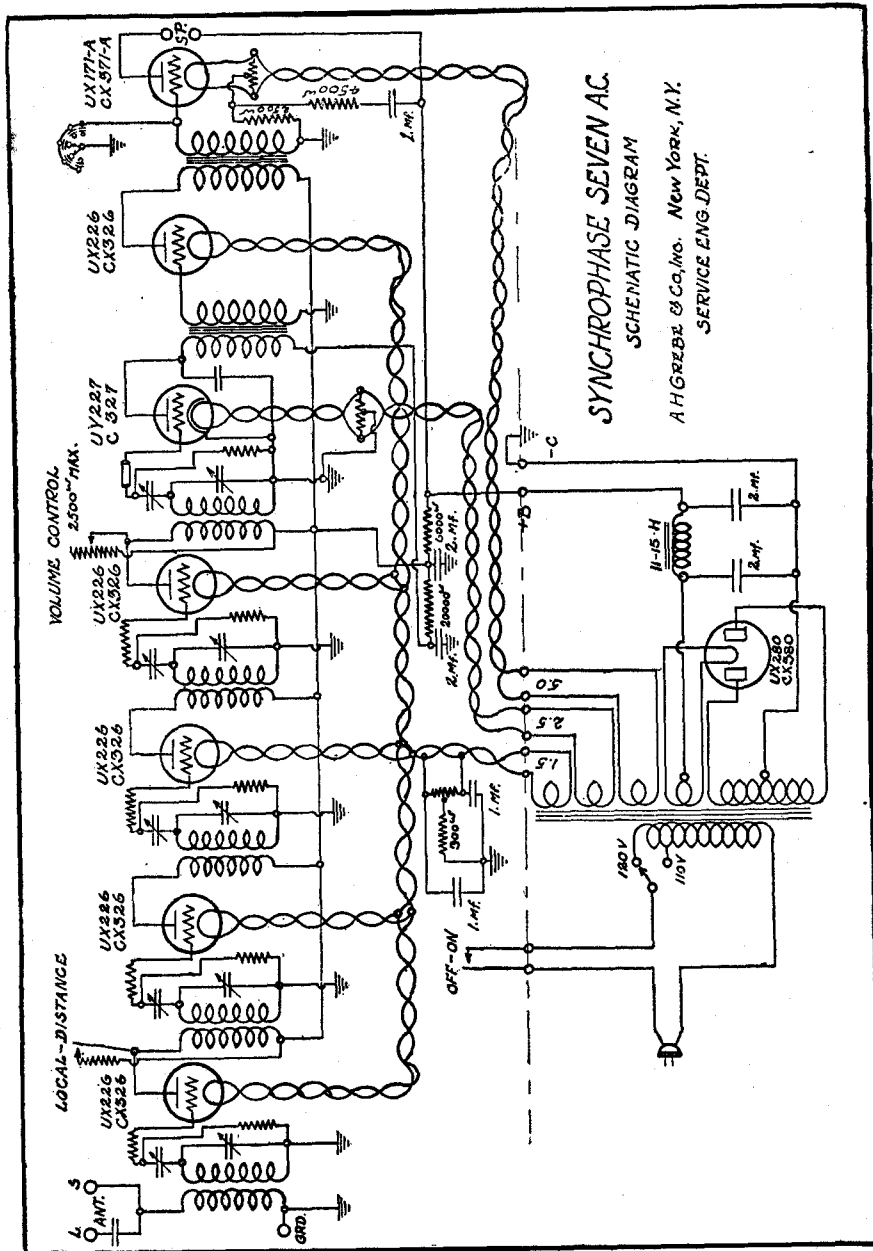

Fig. 2—Wiring Diagram of Synchronphase A. C. 7.

wires are properly bent when the set is adjusted at the factory. The proper bend for these wires is downward to the base.

amplifier chassis. Proper setting of these is made on final test of the set at the factory. However, a sixteenth or

one-eighth of a turn outward will generally correct any oscillating condition. This adjustment should be made very carefully and it should be carried out equally on all of the three adjusting screws. More than one-eighth of a turn may cause a slight change in calibration readings. If these screws are turned out too far the over-all sensitivity of the set is reduced.

In the event the adjusting screws protruding through the deck have been tampered with, it is suggested they be set in their original position as made in the final factory adjustment. This is done by turning the screws down tight and then out three-quarters of a turn on each.

In effecting oscillation adjustments it may be well to keep in mind the following:

No. 1. "Contact Brakes"—adjustments are most effective for correcting the oscillation around 700 to 550 kilocycles.

No. 2. "Gain Screws"—adjustments are most effective for correcting oscillations around 1500 to 1200 kilocycles.

No. 3. Flexible wires—position for correcting oscillations over entire frequency range.

Alignment of Tuning Stages

In order for Grebe receivers to give greatest selectivity and volume it is absolutely necessary that the variable condensers be correctly aligned. For this reason considerable information will be given in this service manual on the theory and method of aligning or adjusting the tuning condensers.

Tuning condensers are generally perfectly adjusted at the factory and should not require any adjustment unless they have been tampered with. These instructions will enable any Radio-Trician to determine whether or not the condensers are correctly aligned or balanced.

EQUIPMENT AND TOOLS.—The following tools and equipment are suggested for the best practical results.

1. Aerial, ground and all tubes necessary for operation of set.
2. Modulated oscillator similar to one described in previous service manual.
3. Inductance loop tool for testing the proper inductance of R.F. transformer.
4. Condenser plate alignment tool.
5. Necessary wrenches and screwdrivers with Bakelite or wooden handles for making adjustments on receivers. (Note: Special tools for balancing receivers can generally be obtained from the manufacturers of the set.)

The inductance or alignment loop is made by constructing a single loop of wire which will just pass over the outside of the R.F. coil. This loop is fastened to the end of a wooden or Bakelite stick so that the loop can be easily placed around or inside the R.F. coil that is being tested.

In some receivers it is necessary to make the loop small enough so that it will go inside the R.F. coil. This is true when there are wires attached to the coil which will prevent the loop from going on the outside of the coil. When testing the inductance of a R.F. coil which is shielded, the shield should be in place. In such cases, it is sometimes possible to insert the loop inside the coil from the bottom of the chassis. In this case it is of course necessary to place the chassis on supports so that the underside of the chassis is readily accessible.

The condenser plate alignment tool is made by fastening an old condenser plate in a slot in the end of a wooden or Bakelite rod so that the plate can be brought close to the plate of the condenser being tested.

TESTING ALIGNMENT.—The theory of the inductance loop, or absorption loop, test is as follows: If a short-circuited coil of wire is coupled loosely to an inductance coil this coil will decrease the inductance of the coil and the circuit will therefore be tuned to a lower wavelength than that to which it was tuned before the loop was introduced into the field. Thus this test reduces the inductance of each stage to determine whether the reduction brings that stage more closely into alignment with the others. If this happens it is evident that the wavelength of the stage was originally too high and must be reduced to affect correct alignment. In this connection it is well to state that it is not advisable to attempt to reduce the inductance of a radio frequency coil by removing wire from the coil. The wavelength of the stage can be decreased by slightly decreasing the capacity of the tuning condenser as will be explained later.

The condenser plate test is based on the theory that bringing the extra condenser plate in close proximity to the plates of the tuning condenser increases the capacity of the condenser and will of course increase the wavelength to which that particular radio frequency stage is tuned.

In actually testing the alignment of the condenser the modulated oscillator

should be placed in operation and the signal tuned in on the receiver. The volume of the receiver should be ad-

justed so that the volume of the signal is just plainly audible. One side of the condenser plate testing tool is placed on the fixed or stator plates of the variable condenser to be tested. The plate is then slowly tilted toward

that the capacity of the condenser is too low for that particular stage and the condenser should be adjusted so that it will have slightly greater capacity. If the signal decreases it is an indication that the condenser is correctly adjusted or that the capacity of the condenser is too great.

The same test can be accomplished by bringing the condenser plate tool up close to the radio frequency coil, if the coil is not shielded. This has the same effect as increasing the capacity of the condenser.

Using the inductance loop, the loop should be slowly placed around the radio frequency coil. If the signal increases the condenser adjustment should be decreased slightly. However, if the signal intensity decreases it is an indication that the capacity setting is correct or too low.

By carefully conducting these tests the Radio-Trician can readily determine just which radio frequency stage is not correctly balanced and can make the necessary adjustments on the condenser to give greatest signal strength. The adjustments should be made on both the high and low frequency. It often happens that it is not possible to adjust the receiver for best operation on the low frequencies and at the same time receive satisfactory operation on the high frequencies. In this case it will, of course, be necessary to adjust the condensers for best all-round operation.

Owing to the mechanical construction of some receivers it will be impossible to apply both the inductance loop and the condenser plate tests. In this case, either one of the tests will generally enable the Radio-Trician to correctly balance the set. In fact, it is often not necessary to apply the inductance loop test. Another test that is practically the same as the condenser plate test is to place a wooden or Bakelite rod on one of the stator plates of the condenser. Pushing in slightly on this plate will increase the capacity of the condenser and will, of course, indicate whether or not the condenser is adjusted correctly.

An increase in volume always indicates that the capacity is incorrect, too high in the inductance loop test and too low in the condenser plate test. A decrease in volume resulting from either test when applied individually would have no definite meaning, both tests must be applied to determine if stages are correctly aligned.

Alignment of A.C. 7 Model
FIRST OPERATION — "LOW" ALIGNMENT. Tune the oscillator to some wave length near 200 meters, or, if no oscillator is available, select a nearby broadcasting station in this range. The equivalent Synchrophase Seven dial reading must be between 6 and 20 degrees. Tune the set for maximum response to this signal as described in the above; the aligning or grid condensers are located to the left of the resistance mountings at the rear of each of the tuning condensers. The detector aligning condenser (extreme right of set) should be screwed all the way in. With the Bakelite wrench, tighten or release those of the four preceding stages as necessary to bring them into alignment, as indicated by increased signal strength. When these corrections have been made, the stages are correctly aligned for low wavelength reception. Adjustment by means of these grid alignment condensers is only effective on the lower dial settings.

SECOND OPERATION — "HIGH" ALIGNMENT. Tune the oscillator to about 520 meters, equivalent to about 90 degrees on the Synchrophase Seven dial, and tune the set to maximum response to this signal. To determine the accuracy of alignment for high dial settings, each stage is tested in turn as previously described in the first part of this service manual.

The capacity may be reduced by bending the upper and lower rotor plates apart carefully. The capacity of any condenser may be increased by bending the upper and lower rotor plates closer to the adjacent stator plates. A very small bend should suffice as the capacity increases very rapidly as the plates are brought closer together. Care should be taken that the plates are not bent sufficiently to short-circuit the condenser.

THIRD OPERATION — "INTERMEDIATE" ALIGNMENT. Tune the oscillator to about 325 meters, corresponding to about 50 degrees on the Synchrophase Seven dial and again tune the set carefully for maximum response. Follow the same procedure as for the "High" alignment, making the two tests to insure that the stages align properly at intermediate dial settings.

FOURTH OPERATION — FINAL "LOW" ALIGNMENT. To insure that the alignment at low dial settings has not been changed by adjustments that

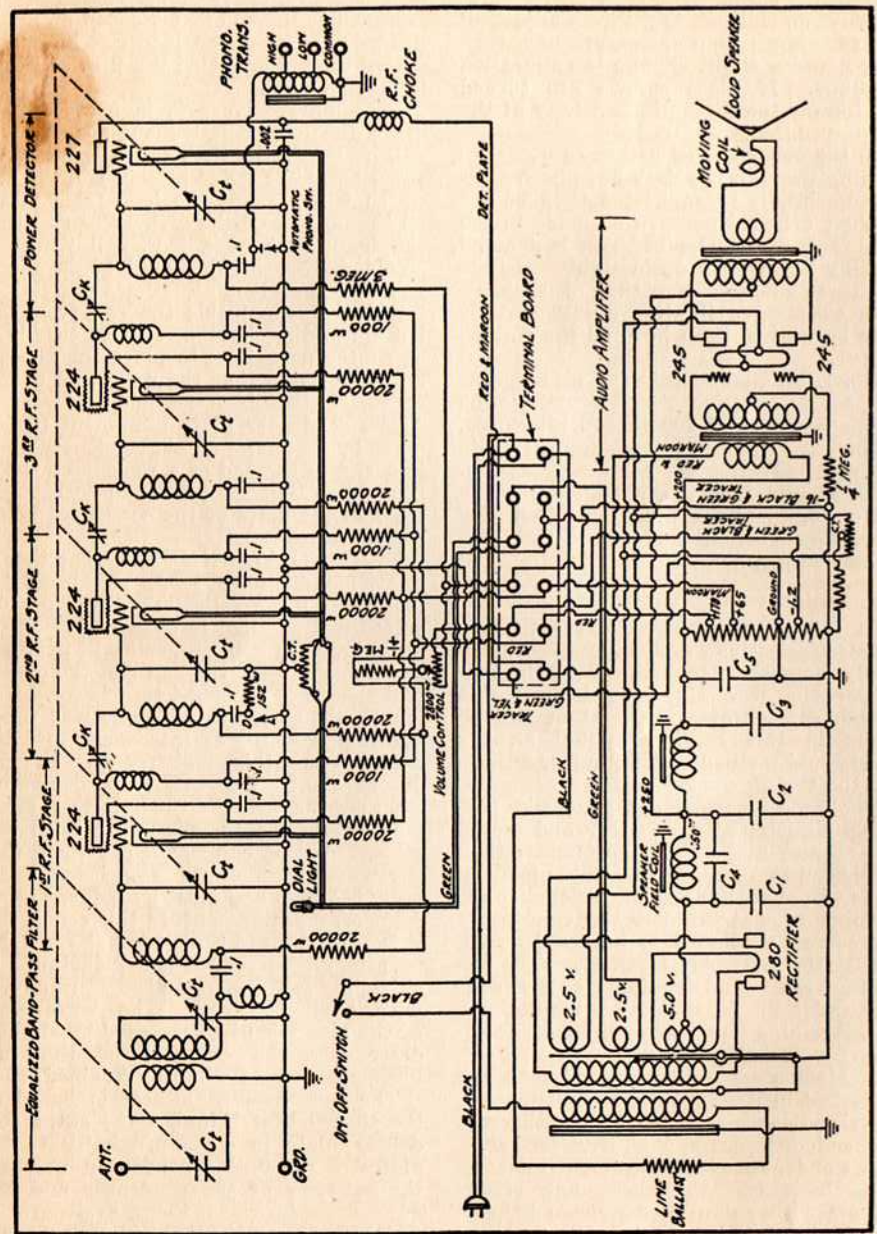

Fig. 3—Wiring Diagram Super Synchrophase SK-4 Screen Grid Receiver.

justed so that the volume of the signal is just plainly audible. One side of the condenser plate testing

the other plate of the condenser, thus increasing the capacity of the condenser. If the signal increases it is then a sign

may have been found necessary at higher settings, repeat the "Low" alignment test of the First Operation. Any slight resetting of the aligning condensers will not affect the accuracy of the "High" adjustments. The two alignment testing tools may be used to facilitate this inspection.

Aligning the Super-Synchrophase Screen Grid Receiver

After determining whether or not the condensers are correctly aligned the following instructions should be followed out in making the adjustments necessary.

CORRECTIVE ADJUSTMENT. The alignment adjusting screws control small condensers which allow a variation of condenser sections to be made. The capacity of a particular section may be increased by tightening this adjustment or reducing by loosening.

These minimum adjusters are effective for alignment of the condensers around 1400 kilocycles setting. They are not very effective nor is it generally necessary to change their adjustment for alignment around 800 or 550 kilocycles. Alignment of condenser sections on these frequencies is best carried on by applying the tests already described and bending slightly the outer rotor plates to the condenser units. This should be done with a condenser plate alignment tool, or with a light duty screwdriver.

NOTE: Method of bending condenser plates. The necessary reduction for capacity should be divided between the two plates by bending out both rotor plates equally. It is desirable that a little bend be made on each plate rather than all on one. The bend is applied only to the large end of the plate. Bending of condenser plate to take care of increase or decrease in capacity should be done on the rotor plate where it meshes with the stator when an off alignment condition is found.

Capacity of any condenser section may be increased by carefully bending the outer rotor plates closer to the adjacent rotor plates. A very small bend should suffice as the plates are brought closer together. Great care should be taken that the plates are not bent sufficiently to short-circuit the condenser.

SETTING ADJUSTABLE GAIN SCREWS. See paragraph on page 4.

REMOVE CHASSIS FROM CONSOLE. In making the alignment opera-

tion, it is necessary that the radio chassis be removed from the console and the condenser cover be removed. The radio chassis must not be placed directly on the table or over any metal work. Chassis should be raised about 2" off the table. It may be supported on the four corners by wooden blocks or similar type of support. If this is not done, erroneous alignment adjustments will be obtained. It will be noted that in the console installations the cabinet is cut away under the radio chassis to avoid such difficulty in regular operation.

FIRST OPERATION — "LOW" ALIGNMENT. Tune the oscillator accurately to some frequency near 1400 kilocycles. If no oscillator is available, select a nearby broadcasting station in this range. Tune the set for maximum response to this signal as previously described. The alignment condensers for each variable condenser unit necessary to be adjusted is located in the rear on the condenser frame. Starting with the alignment condensers on the extreme right of the set, tighten or release the settings of the alignment screws as necessary to bring the condensers into alignment with each other as indicated by increased signal strength. When these corrections have been made, stages are correctly aligned for low wave reception. It should not be necessary to change the adjustable screws for other frequency adjustments.

SECOND OPERATION—INTERMEDIATE ALIGNMENT. Tune the oscillator to approximately 800 kilocycles and tune the set to perfect resonance to this signal. To determine the accuracy of alignment for intermediate settings, each stage is tested in turn by using the special inductance loop test already described.

It is advisable to apply this test to each of the 5 stages in turn, noting what stages need correction. When these corrections have been made test with the condenser plate tool. When correction required by this test has been made, accuracy of each adjustment must be checked by applying both tests to each stage.

THIRD OPERATION—HIGH ALIGNMENT. Tune the oscillator to about 550 kilocycles. Again tune the set carefully to a maximum response. Follow the same procedure as for the intermediate alignment, making the two tests to insure that the stages are aligned properly.