

NATIONAL RADIO INSTITUTE

Washington D. C.

# Radio-Trician Service Manual

Compiled solely for  Students & Graduates

ON

## SERVICING B-POWER SUPPLY UNITS

There are very few elements to cause trouble in a standard "B" eliminator using the B or BH type Raytheon or filament type of rectifying tubes. However, when trouble does develop, it may be readily located and remedied. Therefore, the follow-

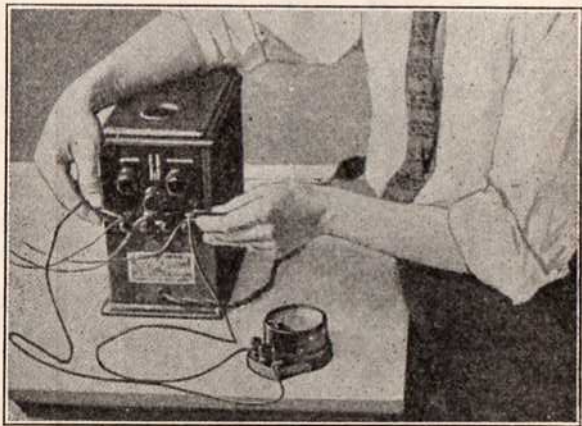

Testing the output voltage of a Battery Eliminator with a High Resistance Voltmeter.

ing suggestions given in this Service Manual should be very helpful to Radio-Tricians in facilitating such work; take for example, Figure 2, which shows the circuit diagram of a standard B eliminator using Raytheon rectifying tube, and Table I describes the ordinary troubles encountered in such a unit.

### SERVICE DATA

#### Low Voltage at Output Taps.

The logical place to begin looking for trouble in a B eliminator is at the resistor banks, R1, R2 and R3, and then work backwards through the filter, the rectifying tube, and finally,

TABLE I

Trouble	Usual Cause
No Output	Defective Rectifier Tube. Make Complete Test.
Slow Starting	Defective Rectifier Tube.
Irregular Operation	Defective Rectifier Tube. Loose Connection.
Low Output Voltage on All Taps	Defective Rectifier Tube. Low Line Voltage (A. C. Supply.) Defective Condensers C1, C2 or C3. Defective Condenser C5. Partly short-circuited Transformer.
Low Detector Voltage	Defective Condenser C4. Resistance too low R3. More than 1 tube supplied from detector.
Low 90-Volt Output (B Amp. +)	Defective Condenser C5. Resistance R1 too high.
No Detector Voltage	Condenser C4 short-circuited. Resistance R3 short-circuited.
No 90-volt (B Amp. +) and Detector	Condensers C5 and C4 short-circuited. Resistances R1, R2 and R3 short-circuited.
High Detector Voltage	Resistance R2 short-circuited. Resistance R2 too low.
High 90-volt (B Amp. +) Voltage	Resistance R1 shorted.
Excessive Hum	Defective Tube Condensers C1, C2, C3 disconnected. Defective Chokes L1 and L2.
Excessive Current Consumption	Transformer partly short-circuited. Condensers C6 and C7 short-circuited.
Motorboating	See Receiver "Service Information."

the power transformer. It is assumed, of course, that the 110-volt alternating current supply is known to be flowing through the transformer primary when the B eliminator is turned on,

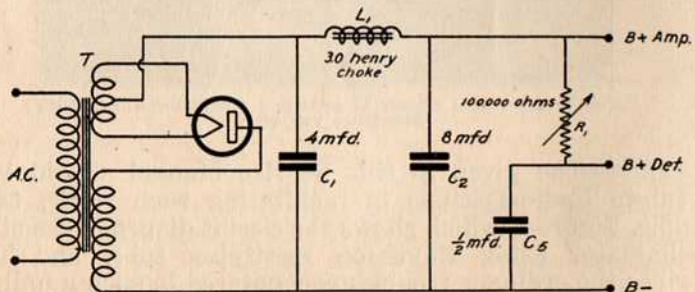

Fig. 1—"B" Power Supply Circuit using Half-wave Filament type of Rectifier Tube.

and that the rectifying tube is not visibly damaged in any way. Of course, the current should be turned off before any part of the B eliminator is handled to avoid any dangerous shock.

An open circuited or burnt out resistor will result in no voltage from the tap it controls. If the fixed resistor, R3, becomes open circuited, in the case of the B eliminator, the detector voltage will immediately increase so that in the tuned high frequency type of receiver, the signal strength will be greatly diminished, while in a regenerative receiver there will be constant oscillations.

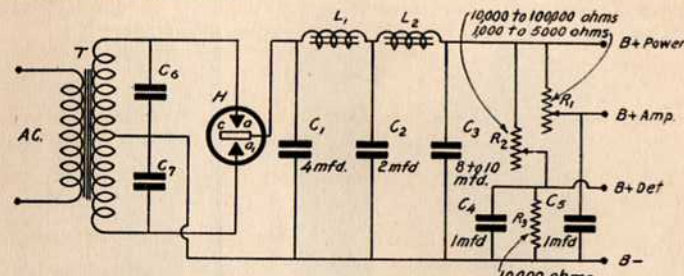

Fig. 2—The Raytheon Full-wave Rectifier Circuit for "B" Power Supply.

The simplest method to locate a defective resistor is by means of a high resistance voltmeter connected to each tap in turn. In fact, this device is essential in adjusting B power voltages on any receiver. In the absence of a high resistance voltmeter, a 15 watt, 220 volt incandescent lamp may be employed. It should glow a dull red on the full output and on the intermediate tap of the B eliminator. If it lights equally bright on the detector tap, this is an indication of an open or defective fixed resistor, R3.

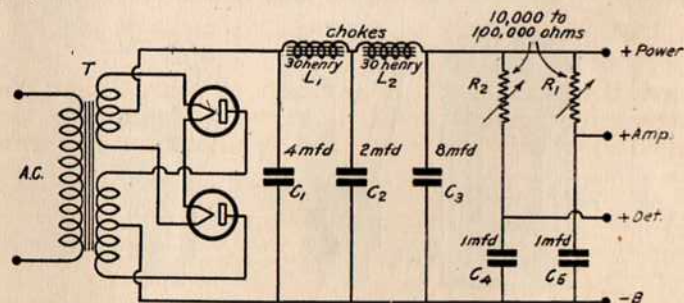

Fig. 3—"B" Power Supply using two Half-wave Filament type Rectifying Tubes for Full-wave Rectification.

If the tap voltages are found satisfactory, and the receiver still does not operate well, the trouble may be due to an open circuited or an omitted by-pass condenser C4 or C5. A short circuited by-pass condenser will act the same as a short circuited resistor.

**No Voltage at all Terminals.**

This condition can be caused by an open circuit in the wiring, transformer, choke coils, or a broken down filter condenser. With the power supply line disconnected from the B elimi-

nator, and the rectifying tube removed, a click should be heard in the testing headphone when connected in series with a battery between the C terminal of the rectifier socket and the B positive terminal of the B eliminator. A click should also be heard between the terminals A and A1 of the rectifier socket and the B negative terminal of the B eliminator. These clicks should be of equal strength. If one terminal gives a much louder click

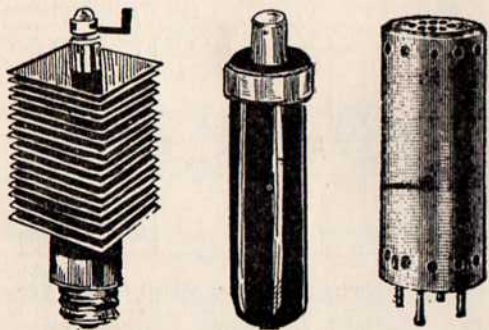

Metallic Rectifiers

than the other, it generally indicates a defective filter condenser, C6, C7. If no click is heard on either terminal A or A1, then the transformer secondary is open-circuited or the center tap of the transformer does not connect to the B negative side as it should.

The circuit continuity of the transformer itself may be tested by the click between the two terminals A and A1 of the rectifier

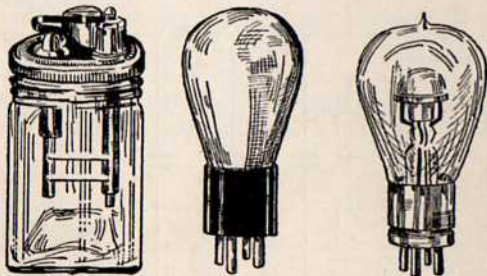

Cell of Electrolytic Filament Lighted Ionized Gas  
Various types of Rectifier units used in Battery Eliminators

socket, with the rectifying tube removed. If the transformer secondary tests O. K. on the foregoing procedure, there must of necessity be an open circuit in the B negative lead.

A short circuit in the secondary of the transformer can be easily checked by connecting a 25 watt, 110 volt lamp in series with the primary. The current may be turned on in the usual way but with the rectifying tube removed from the socket. The incandescent lamp should glow dully, if at all. If it glows brightly, either the transformer secondary or one of the 0.1 mfd. filter condensers, C6 or C7, is broken down. With the lamp still

in the primary, the rectifying tube is inserted in the socket. If the secondary connections are O. K. and the rectifying tube is operating, the lamp will increase in brilliancy. The filter condensers, if defective, may be disconnected from the transformer secondary and rectifier socket so as to be tested separately for short circuit.

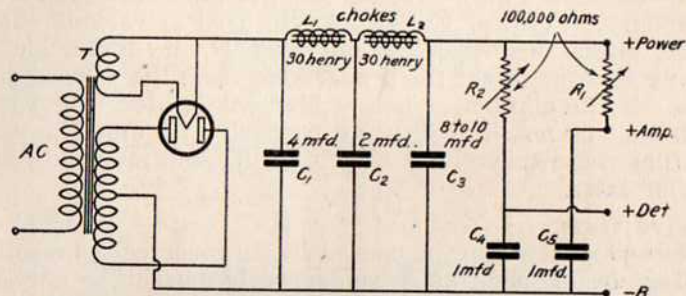

Fig. 4—Full-wave Rectifier Circuit for "B" Supply using a Filament type of Tube.

To test a condenser after it is removed from the eliminator, it is first discharged by holding a piece of wire or metal across its terminals for the charge it contains may cause a click in the phones, which will give a false impression that the condenser is short circuited. If the condenser is in good condition, there will

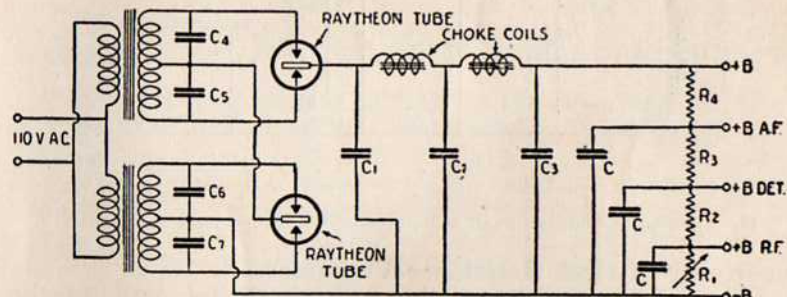

Fig. 5—Circuit diagram of B Power Unit, employing two Raytheon tubes and two transformers having an output of about 435 volts D.C.

be little or no click the second time its terminals are touched. But if short circuited, a distinct click will be heard in the headphones each time the condenser terminals are touched, and again when the tips are removed.

#### Testing the Raytheon Tube.

A Raytheon tube can be depended upon to provide satisfactory service for about a year of normal use, at least one thousand hours of radio entertainment. After serving nearly its full life, the voltage output of the tube, previously maintained at a uniform high level, begins to drop off. When such a condition is obtained, the voltage controls can often be adjusted to bring the voltage up again to the desired value, and many weeks more of

good reception enjoyed before the tube is finally discarded. If the Raytheon tube gets warm when the B eliminator is in operation, it is sufficient indication that the rectifier tube is operating.

If the rectifier is of the electrolytic type, such as the Philco or Balkite, the electrolyte may have evaporated, or it may be too low for the proper operation of the device.

The electrodes may have become decomposed, which necessitates renewal. (Note) the electrolyte used in various chemical rectifiers differ considerably, therefore it is very important when replacing solution to get the proper kind from the nearest service station. If the eliminator uses a filament lighted tube rectifier, see whether or not it is lighting properly. It must be remembered that these tubes have a definite life and must be renewed sooner or later.

### Excessive Hum.

This condition may be caused by an incorrect connection in the filter circuit, such as a condenser by-passing a choke coil. The hum should increase when either choke coil is short circuited in turn. If the hum does not increase, the circuit connection to that choke coil should be checked, and if found correct, then the choke coil should be replaced by another one of similar characteristics.

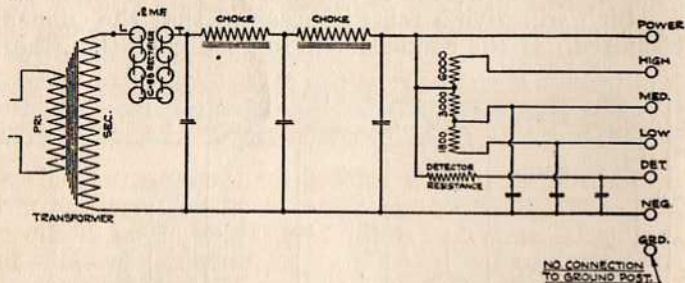

Fig. 6—Balkite B Supply Circuit using Electrolytic Rectifier type B-180 Form B.

### Importance of High Resistance Voltmeter.

Those desirous of operating a B eliminator or a Raytheon ABC power pack, as the case may be, should have a voltmeter whose resistance is at least 100,000 ohms, with a full scale deflection of 200 or 250 volts. Such a meter will permit of adjusting the resistances for the proper output voltages when connected with a given radio receiving set. Not only is this of greatest benefit when the initial installation is made, but it will later be of use in making adjustments to take care of line voltage fluctuations, etc. Correct readings are impossible with the inexpensive low resistance type of voltmeter.

### Motorboating.

Motorboating is a term describing the sound produced in some radio installations such as an unsuitable combination of receiver and B eliminator. This sound resembles the put-put-put of a small gas engine and is usually continuous while the receiver

is in operation. The motorboating is in reality a low frequency oscillation produced by high common impedance in the plate circuit of the audio amplifier. The common impedance is usually found in the output system of the B eliminator. In some combinations of receiver and eliminator, conditions will be such that the tendency for unstable operation is present, and motorboating will take place. In other combinations, the relation may be such that motorboating is prevented. The first remedy, therefore, is the substitution of a different type of eliminator in the installation. Where this is impossible or ineffective, other remedies must be sought.

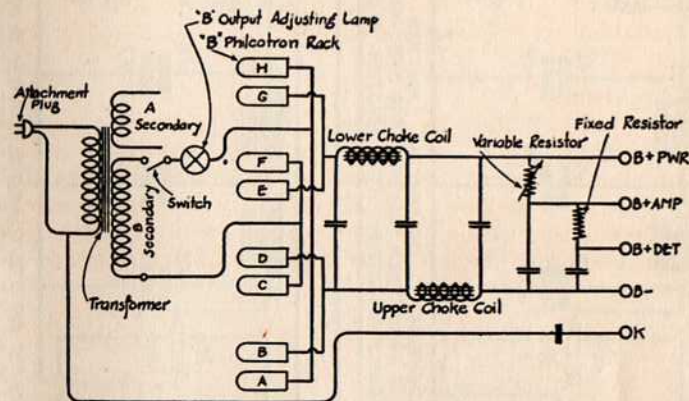

Fig. 7—Philco "B" Supply Circuit using Electrolytic Rectifier types 663, 623, 463, 423.

The use of a separate B battery for the detector plate supply will often cure motorboating. The negative terminal of the B battery must be connected to the negative B of the B eliminator, and the positive to the detector + 45 terminal or cable lead of the receiver. Other connections must be left as before. The drain on the battery is extremely low and, therefore, replacement will be infrequent. In the case of a transformer coupled audio amplifier, reversal of the primary connections to one of the transformers may prove effective by changing the phase relation in such a manner that the receiver will not motorboat.

This method is impossible with resistance coupled amplifiers. The substitution of a high grade low ratio audio transformer for a resistance coupled stage will increase the volume without impairing the tone quality. Proper connection of its primary may prevent motorboating.

A 2 to 4 mfd. condenser may be connected between the negative B and the detector plate supply. If not effective, a 30 henry choke coil may be added, connected between the plus B detector and the condenser.

It is difficult to predict the success of any particular remedy. It is suggested that the methods be tried in the order of ease of application.

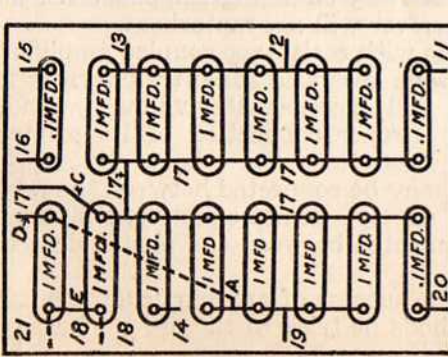

**CROSS SECTION OF CONDENSER BANK**  
 1- ABOVE CONNECTIONS CONNECT TO OTHER APPARATUS ACCORDING TO NUMBER DESIGNATION.  
 2- IN SPECIAL MASTER CONDENSER STRAP, A-B'S NOT SHOWN OR USED. LEAD C'S CONNECTED TO LEAD D'S. THESE TWO UNITS IS THEN MADE AS SHOWN BY DOTTED WIRING (B&2).  
 3- IN ALL OTHER MODELS USE STRAP A-B' AND ALL WIRING SHOWN AS SOLID (NOT DOTTED).

**"NOTE"**  
 THE WIRING ON CONDENSER BANK AS SHOWN ON CROSS SECTION VIEW IS ALL CONCEALED WITHIN THE BANK

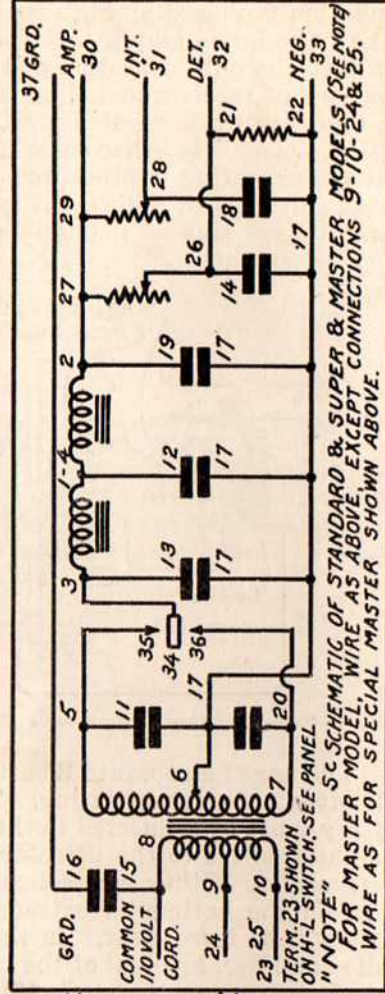
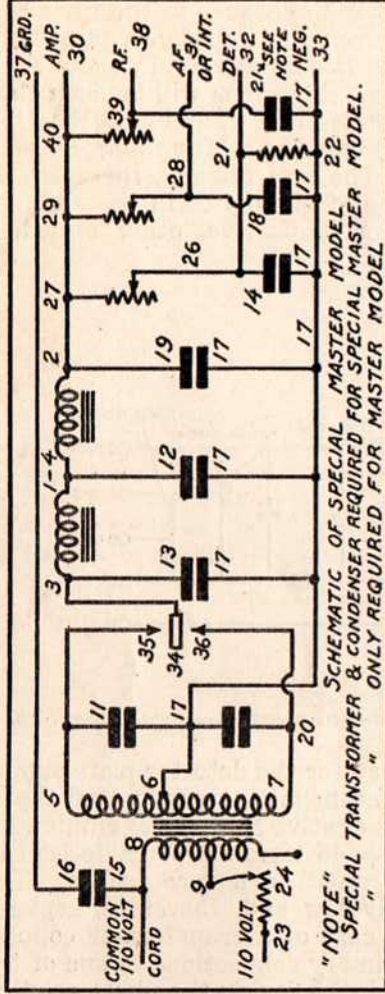

Fig. 8—Circuit Diagram of Majestic "B" Eliminators.